



HEADWIND

The Monthly Newsletter of the
Tokay Radio Control Modelers
Lodi, California



AMA District 10

FOUNDED 1971 AMA CHARTERED CLUB 1251 WWW.TOKAYRCMODELERS.COM

Next Meeting:
Wednesday
June 1st, 2016

2016 TRCM Officers:

President: Bob Kellar
president@tokayrcmodelers.com

Vice-President: Randy Laney
Vice-
president@tokayrcmodelers.com

Secretary: Dennis Campbell
secretary@tokayrcmodelers.com

Treasurer: Robert Stanley
treasurer@tokayrcmodelers.com

Safety Coordinator: John Lett
safety@tokayrcmodelers.com

Newsletter: Mark Huntley
headwind@tokayrcmodelers.com

Webmaster: Hal Singer
webmaster@tokayrcmodelers.com

TRCM Events 2016

TRCM 5th Annual
IMAC Contest June
11th & 12th, 2016

TRCM 4th Annual
Giant Scale Fun Fly
July 9th

Presidents Message Bob Kellar

Well, I guess we all knew it was coming but still, it is a pain in the derriere. What, you ask am I referring to? The continuous election drivel? The next breathless change in Kim Kardashian's wardrobe? The fact that the Russian athletes used performance enhancing drugs? The fact that the Sacramento Kings still have a dysfunctional organization? That the Giants will be competitive for the National League Pennant again this year? No...all these things are not important to us Tokay RC'ers. What I am referring to is the WIND. Every Spring we have to deal with the wind interfering with our flying. At our field, we have two typical wind directions. The first is South, Southwest. This is usually the result of onshore flow through the Golden Gate. It is usually worse in the afternoon and if it is blowing in the morning, the afternoon can be very blustery. The other direction is North, Northwest. This direction is the worst for our field as it is almost ninety degrees in crosswind. For most of us mortal fliers, flying is impossible.

So how can you predict what is going to happen the next day when you are making plans about flying the next day? (We are very fortunate to have an Intellicast Weather Station very close to our field for current conditions. See our website, Tokayrcmodelers.com, or directly on Intellicast.com and enter Walnut Grove, CA for a current report.) When you watch the TV weather report the night before look for two factors. One, if the coastal stratus is shown as thick or coming in, the onshore flow direction, South, Southwest winds will probably come back in the middle of the day and worsen in the afternoon. Second, if the lines of equal barometric pressure (these are the lines that

look like a bunch of railroad tracks) run North to South and are close together, we are going to have that dastardly North, Northwest wind. The closer the lines are together, the stronger the wind will be. There is usually no morning calm as the North wind will blow all day, though it may strengthen in the afternoon. This frequently results in unflyable conditions. Maybe these little facts will help you decide whether to make that 20 mile drive to the field.

Our IMAC contest is coming up in June and I encourage all of you to come out to the field and watch some of the flying. If you have a club cap or hat or T-shirt, wear that to show your pride in our club. If you have time to spare, offer to help in the contest. Even if it is for just one hour, you can be put to work and it is fun to help these great flyers compete. I know I learn some little trick every time I watch or help out. Just find any of the officers and offer your help. We will give you something fun and interesting to do.

I am looking forward to seeing you at the June meeting and the IMAC contest.



TRCM MEETING MINUTES

Meeting was held on May 4, 2016 at 6:30 pm at the Lodi Public Library.

I. Call to Order: President Bob Kellar, 6:30 pm

II. Announcements from the Floor:

Bill Churchill announced that the date for the Summer BBQ has been changed to Sunday August 14, 2016. Greg Hennefer addressed the issue of the gate not being locked properly. A sign explaining the lock up procedure was installed on the gate. It is pretty straight forward so hopefully we won't have problems with people locking the gate the wrong way. It has to be locked so our members can get in and also so the farmer can get in! Greg also said that Mitch Biddle has also done the shopping for the new pilot station fence material. Stockton Fence Company has it in stock. The fence material will be made of green vinyl clad chain link fence material.

III. Visitors and New Members:

We had 19 members and 2 guest present. Guests Mervin Ory and Chris Mathews were voted in as new members.

IV. Officers Reports:

President: Bob Kellar Present

Vice-President: Randy Laney Absent as he was on vacation.

Secretary: Dennis Campbell: Present

Treasurer's Report: Robert Stanley: Gave his monthly treasure's report.

Safety Coordinator: John Lett Absent as he was at an out of state R/C Event.

News Letter Editor: Mark Huntley Absent, but it was noted that Garrett Morrison won the Name the plane contest.

Webmaster: Hal Singer: Said there is a new roster button on our web page.

Field Marshall: Mitch Biddle: Absent but him and Greg Hennefer mowed the weeds today. Also Mitch cleaned the weeds out of the seams on the runway! Bob Kellar sprayed the weeds with Ground Clear, so that should take care of those weeds for the rest of the year!

V. Old Business:

1. Hal Singer made a motion to spend the money to purchase the fence material. Don Brown seconded the motion. The motion carried.
2. Dennis Campbell thanked Hal Singer, Rob Stanley, Mike Wilson and Rosemary Kellar for helping with the 4th and final Swap Meet and Indoor Fun Fly. Due to low attendance we decided not to have this event any longer.
3. Hal Singer said that we will be able to have our Sweet Heart Dinner at Burgundy Hall this year!
4. Randy Laney was absent but Greg Hennefer said that he will bring 250 gallons of water so Randy can use his pressure washer to wash the tables and chairs at the flying field.
5. Bob Kellar gave an update on the flight simulator. He read a hilarious letter from Bill Churchill about how he wasn't going to let a bunch of kids out smart him on making a joy stick that they couldn't destroy! He said that he knows people that know people who he can call if he needs help designing a non-destructible joy stick for the simulator! He has taken it on as a challenge now! Good luck with that Bill.
6. Greg Hennefer gave us an update on the price of shirts for the IMAC event. After some good discussion on this matter a motion was made by himself to spend money to purchase 75 red shirts of various sizes. Al Doucette seconded

The motion carried.

7. Dick Wareham said that he has 200 TRCM Name Badges for sale. Please see him if you would like to purchase one.
8. Garrett Morrison said that we will need to provide temporary shade structures for the IMAC event.

VI. New Business:

Don Brown told us about a recent event that he had while flying one of his electric airplanes at a Lodi Park. He said that he was told by a city employee that was working at the park that he wasn't allowed to fly there because his airplane is considered projectile. Long story short the police were called and he was told by the officer that he couldn't fly there.

Don, not being happy with that outcome, wrote a letter to the City Manager. He also told Don they are considered projectiles and he is not allowed to fly them in the City Park. Don wants to know if the club wants to get involved and help him fight this fight. Hal Singer said that he has talked to the City Attorney about this some time ago. He said that the City Attorney wrote the law and he doesn't think the club should get involved with Don on this issue. Don will have to pursue it by himself if he wants to continue down this road with the City.
Sign up for IMAC jobs were postponed until next month's meeting.

VII. Show and Tell:

Al Doucette brought in his scale 70's vintage Chinook helicopter in for show and tell. He said that he converted it to electric and he uses A123 batteries in it. He brought his transmitter with him and gave us a little running demonstration on it. Very cool! Dennis Campbell brought in his Mini Stick for show and tell. He said that he wanted to put a set of floats on it so he could fly it at New Hogan Reservoir. Hal Singer said that his electric Tundra came with floats and he could borrow them if he wanted to. Dennis took him up on it. He said that he can't wait to give it a try!

VIII. Awards:

1. ACE: Bill Churchill was awarded the ACE Award for his warranty service on the Flight Simulator!
2. OOPS: Mike Mancebo crashed his Ugly Stick in the field and it is still out there! Don Brown said that he had a confession to make. He said that he drives a Ford Edge and that when you lay the back seat down it automatically moves forward. Well he had his JR Transmitter laying on the floor of the back seat, so when it automatically moved forward it squeezed his transmitter between the two seats. It destroyed the LCD monitor portion of the radio. He said even though he couldn't see the screen to make adjustments etc. it still worked. In fact he used it to fly his IMAC airplane in a contest the next weekend! Don Brown was this month's winner of the OOPS Award.

IX. Raffle:

Don Brown won the card draw for the new DLE 30cc engine, but no luck this time! Greg Hennefer won the dice roll for the Power Meter and won it! Congratulations Greg!

X. Meeting adjournment: 7:58 pm

Respectfully submitted by: Dennis Campbell



~ June 11 & 12, 2016 ~

Tokay RC Modelers 5th Annual IMAC Contest!

- All Classes
- Pilot Raffle Prizes
- Breakfast & Lunch both days
- Beginners Welcome—Help Available
- Freestyle Show to Music Sat & Sun at Noon!
- No Charge for Spectators or Parking
- Free Overnight Camping for Contestants
- Field Open Thursday & Friday for practice

Hosted by Tokay Radio Control Modelers - Lodi, California

Information: www.TokayRCModelers.com



Tokay Radio Control Modelers Presents:

4th Annual Giant Scale Fly In Saturday, July 9, 2016

Tokay RC Modelers invites you to "GO BIG!"

- ♣ AMA Sanctioned Event
- ♣ Open to any type plane (no turbine jets)
- ♣ 25% scale or larger
- ♣ No Landing Fee!
- ♣ Flying starts at 8:30 until ??
- ♣ 630' x 56' Runway
- ♣ Plenty of shade and parking
- ♣ BBQ Lunch available
- ♣ Proof of current AMA membership is required
- ♣ Visitors and spectators are welcome, no charge to attend or park.



For info visit our website at www.TokayRCModelers.com

Wally Felahy Email: walifela@hotmail.com

Directions to TRCM's field:

From I-5 exit West onto Walnut Grove-Thornton Road. Proceed for 5.4 miles.

Turn left onto Race Track Road for 1.9 miles. TRCM flying site will be on your left through the gates.

Latitude: 38.205712433018621
Longitude: -121.52655601501465



Mike Wilson just finished this beautiful 95inch Sky Baby powered by a 33cc Turnigy motor. Nice job Mike!



One recent Sunday the weather was pretty good, in other words not too windy! A few of our IMAC fliers came out to the field, Mickey Crawley, Jim Doyle and Don Brown. Mickey and Jim had their new Lazer airplanes there and Mickey put a maiden flight on his. It flew great! Good looking models with different color schemes.

Ken Knowles had his Super Big Stick out for it's maiden flight, this is a big airplane with an old G62 on the nose. It too flew well but vibration was a problem, unscrewing the fuel tank cover screws! It landed before the cover came off!

Brian Lewis had a fleet of three electric ducted fan jets, and had a blast flying them all! Very nicely detailed models.

Regards, Mike







Cleaning out the Hanger (garage) so they all have to go. Reasonable cash offers accepted. More aircraft will be available soon.

Get in touch with me by phone or text at (209) 601-8448 or email at webmaster@tokayrcmodelers.com

Giant Scale Sig Cap 231EX Breitling



Sig Cap 231

Zenoah G-38 engine
Hitec HS645MG servos

Wingspan: 73 in.
Length: 65 1/2 in.
Wing Area: 962.5 sq. in.
Weight: 11 lbs.

All set up, ready to fly, less receiver. New NiMh 2200mah flight battery pack.

All complete, ready to go!

\$400

Parkzone SE5A Electric Biplane



Wingspan 37"
Length 30"
480 Outrunner Brushless 960kV Motor
Eflight ESC

Good condition, needs a little work.
\$55

Parkzone Sukhoi Electric Aerobat

Spektrum AR636 replaced with Spektrum receiver
New 35-42 1250Kv BL outrunner motor
New 50A ESC
E-flite 13-gram digital micro servos

Used and a little battered but flies ok and is a lot of fun. Knife edge loops really impress.

\$100

Associated RC10GT gas car





Associated RC10GT gas off road used car, 1/10th scale. Everything you need to run it including 2 engines: Thunder Tiger .15 and a HPI .12 with pull start. It won it's share of races back in the day. New tires, spare parts, body in great shape, fuel. Only thing it needs is the engine installation needs to be finished, quick job. Comes with JR XR3 transmitter. No charge for the dirt. Also have a new in the box start stand, OFNA Racing Starter Box, 1/10-1/8 cars. \$200 puts you on the track.

Get in touch with me by phone or text at (209) 601-8448 or email at webmaster@tokayrcmodelers.com



Aerobeez 55" EDGE 540 EPP Full Fuse Electric Aerobatic

Wingspan: 55"

Length: 54.7" (without spinner)

Wing area: 617 sq.in

Flying weight: 60 - 65 oz (without battery)

| Engine | Propeller | Servos | Battery | Spinner | ESC |
|----------------|-----------|--------|----------|-----------------|--------|
| HACKER A40-10S | 14X7 | | HS5245MG | 4S 3300MAH 2.5" | 70 amp |

Full fuselage EPP foam Edge 540! Great looking plane and 3D capable. Looks just like the example in the photo.

New in the box, never removed. No electrics, etc. airplane only.

Paid \$170 and shipping and tax.

\$145

NAME THIS PLANE

Each month I will try to come up with something special or unusual for you to guess. Your correct answer will win you 5 free raffle tickets at our monthly club meeting. You must attend to win. Good luck!

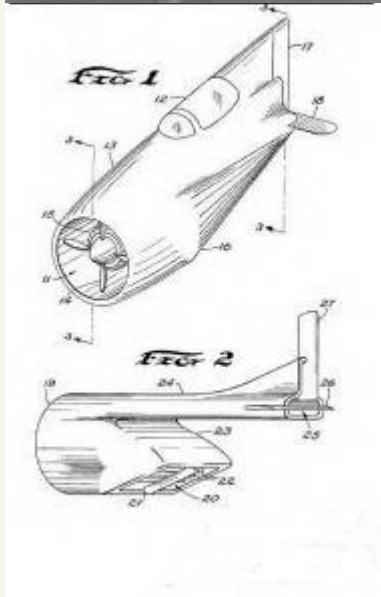



TRCM BADGE ORDER FORM

Clearly print your name, as you want it to appear on your badge. Badges are produced in upper and lower case letters.

First Name: _____

Last Name: _____

Order Quantity: Enter the number of badges you want to buy.

| | Badges with Magnets | Badges with Pins |
|-----------|------------------------|---------------------|
| Quantity: | | |

Cost: \$10.00 each. Includes shipping & handling.

Make check payable to: TRCM. Please do not send cash.

Mail completed form and check to:

Dick Wareham
14024 Islandview Way
Walnut Grove, CA 95690.

Questions? Call Dick at (h) 916-776-4536 or (c) 916-712-8944.

HEADWIND

Permission is granted to reproduce any text content of the **HEADWIND** provided source credit is given.

TRCM members are encouraged to submit articles or ideas for inclusion. Deadline for submissions is two weeks prior to the last day of the month.

Useful Website Links

Of course our TRCM website: <http://www.TokayRCModelers.com>

Academy of Model Aeronautics (AMA): <http://www.modelaircraft.org>

Our AMA District 10 website: <http://www.ama10.org>

For the giant scale flyers, IMAA: <http://www.fly-ima.org>

International Miniature Aerobatics Club (IMAC): <http://www.mini-iac.com>

IMPORTANT: Please make sure when you are the last one to leave the field that you only lock the club padlock through the farmers lock. Do not lock it to the chain as you lock out the farming folks.